

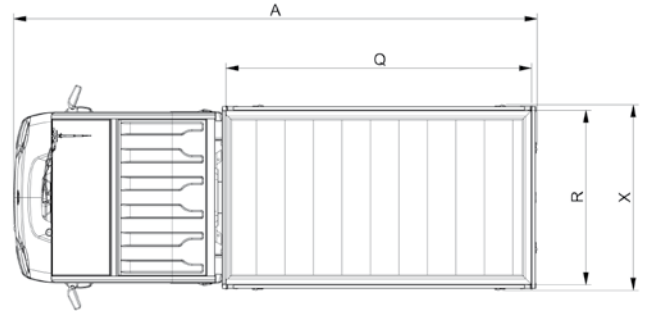

TIPPER

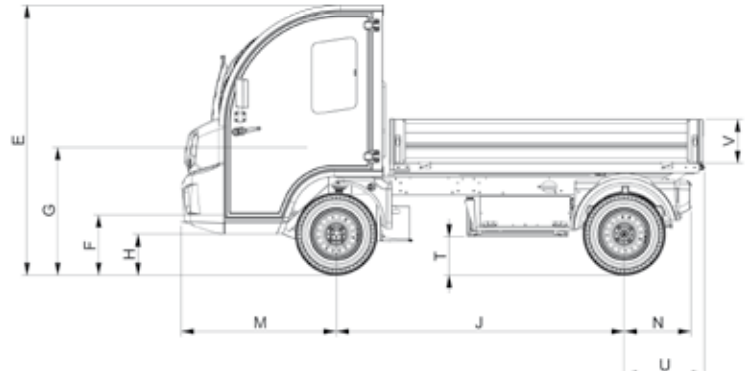
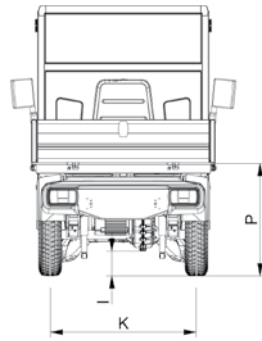
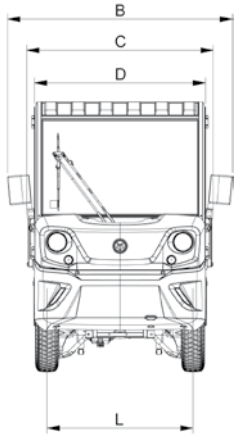

DIMENSIONS (mm)

| A | B | C | D | E | F | G | H | I | J | K | L | M | N | P | Q | R | S | T | U | V | W | X |
|------|------|------|------|------|-----|-----|-----|-----|------|------|------|------|-----|-----|------|------|-----|-----|-----|-----|-----|------|
| 3675 | 1574 | 1305 | 1197 | 1893 | 423 | 897 | 288 | 175 | 2022 | 1021 | 1021 | 1089 | 468 | 788 | 2147 | 1224 | 2,6 | 270 | 564 | 308 | 122 | 1300 |

| BATTERY | Technology | | Plomb Ouvert, élément de 2V | | | Lithium LiFePO4 | |
|---------|-----------------------------------------|-----|-----------------------------|------|------|-----------------|------|
| | Capacity | kWh | 8,6 | 11,5 | 15,4 | 7,2 | 12 |
| | Autonomy (R101 cycle) | Km | 56 | 67 | 90 | 81 | 135 |
| | Battery weight | Kg | 326 | 419 | 493 | 92 | 132 |
| | Charging time | | 8h30 | 7h45 | 9h15 | 3h30 | 5h30 |
| | On board High frequency battery charger | A | 50 | | | | |
| | Power supply | | 230V, 16A | | | | |
| | Auxiliary battery 12 v | | Yes | | | | |

| EQUIPMENT | |
|--------------------------------------------------------------------------------|--|
| • 3 Folding aluminum side panels | |
| • Lifting deck remote control | |
| • Hydraulic cylinder with safety support stand (Compliant with 3.5t standards) | |
| • Optional: Upper mesh cage | |
| • Option: Canvas or Net | |
| • Option: Tie-down rings | |

| PERFORMANCE | Seats | | 2 | | | |
|-------------|-----------------------|----|---------------------------|--|--|--|
| | Type of certification | | N1 | | | |
| | Engine | | AC induction / Asynchrone | | | |
| | Maximum torque | Nm | 57 | | | |
| | Nominal power | kW | 10 | | | |
| | Controller | | Curtis | | | |

| DIMENSIONS & CAPACITIES | Technically permissible maximum laden mass | Kg | 2100 | | | | |
|--------------------------------------------------|-----------------------------------------------|------|------|------|------|------|------|
| | Mass in running order | Kg | 1110 | 1203 | 1277 | 874 | 916 |
| | Load capacity (driver included 75Kg) | Kg | 990 | 897 | 823 | 1226 | 1184 |
| | Towing capacity (unbraked trailer) | Kg | 555 | 602 | 639 | 437 | 458 |
| | Towing capacity (braked trailer) | Kg | 1400 | | | | |
| | Weight of equipment | Kg | 127 | | | | |
| | Load area | m2 | 2,6 | | | | |
| | Useful capacity with upper mesh cage | m3 | 2,9 | | | | |
| | Maximum tipping angle | ° | 47 | | | | |
| | Max height deck raised (with upper mesh cage) | mm | 3089 | | | | |
| Max height deck raised (without upper mesh cage) | mm | 2545 | | | | | |
| Deck time lift (without load) | s | 11 | | | | | |

Changes may occur in the product since the closure of the material edition. Visuals may show equipment or accessories available as standard or optional depending of each country. Technical specifications belong to standard versions, which may vary from country to country. All the characteristics of this document are indicative data; GOUPIL Industrie reserves the right to modify without notice. Please contact your distributor for the latest news.





TIPPER

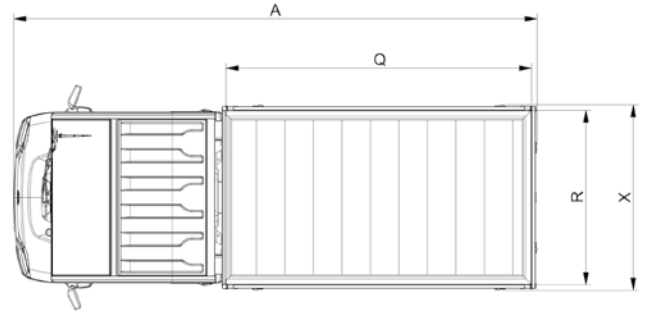
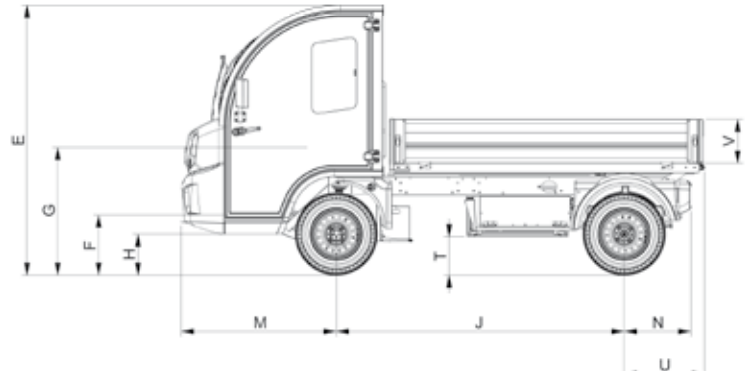
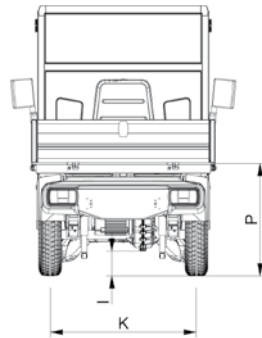
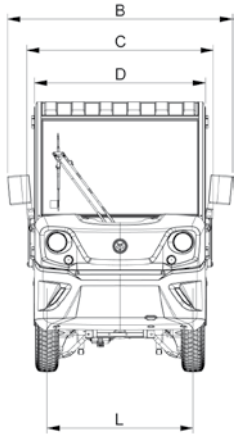

DIMENSIONS (mm)

| A | B | C | D | E | F | G | H | I | J | K | L | M | N | P | Q | R | S | T | U | V | W | X |
|------|------|------|------|------|-----|-----|-----|-----|------|------|------|------|-----|-----|------|------|-----|-----|-----|-----|-----|------|
| 3675 | 1574 | 1305 | 1197 | 1893 | 423 | 897 | 288 | 175 | 2022 | 1021 | 1021 | 1089 | 468 | 788 | 2147 | 1224 | 2,6 | 270 | 564 | 308 | 122 | 1300 |

| BATTERY | Technology | | Lead acid, element of 2V | | | Lithium LiFePO4 | |
|---------|-----------------------------------------|-----|--------------------------|------|------|-----------------|------|
| | Capacity | kWh | 8,6 | 11,5 | 15,4 | 7,2 | 12 |
| | Autonomy (R101 cycle) | Km | 56 | 67 | 90 | 81 | 135 |
| | Battery weight | Kg | 326 | 419 | 493 | 92 | 132 |
| | Charging time | | 8h30 | 7h45 | 9h15 | 3h30 | 5h30 |
| | On board High frequency battery charger | A | 50 | | | | |
| | Power supply | | 230V, 16A | | | | |
| | Auxiliary battery 12 v | | Yes | | | | |

| EQUIPMENT | |
|--------------------------------------------------------------------------------|--|
| • 3 Folding aluminum side panels | |
| • Lifting deck remote control | |
| • Hydraulic cylinder with safety support stand (Compliant with 3.5t standards) | |
| • Optional: Upper mesh cage | |
| • Option: Canvas or Net | |
| • Option: Tie-down rings | |

| PERFORMANCE | Seats | | 2 | | | |
|-------------|-----------------------|----|---------------------------|--|--|--|
| | Type of certification | | L7e-CU | | | |
| | Engine | | AC induction / Asynchrone | | | |
| | Maximum torque | Nm | 57 | | | |
| | Nominal power | kW | 10 | | | |
| | Controller | | Curtis | | | |

| DIMENSIONS & CAPACITIES | Technically permissible maximum laden mass | Kg | 2100 | | | 1800 | |
|--------------------------------------------------|-----------------------------------------------|------|------|------|------|------|-----|
| | Mass in running order | Kg | 1168 | 1261 | 1335 | 932 | 974 |
| | Load capacity (driver included 75Kg) | Kg | 932 | 839 | 765 | 868 | 826 |
| | Towing capacity (unbraked trailer) | Kg | 291 | | | | |
| | Towing capacity (braked trailer) | Kg | 291 | | | | |
| | Weight of equipment | Kg | 127 | | | | |
| | Load area | m2 | 2,6 | | | | |
| | Useful capacity with upper mesh cage | m3 | 2,9 | | | | |
| | Maximum tipping angle | ° | 47 | | | | |
| | Max height deck raised (with upper mesh cage) | mm | 3089 | | | | |
| Max height deck raised (without upper mesh cage) | mm | 2545 | | | | | |
| Deck time lift (without load) | s | 11 | | | | | |

Changes may occur in the product since the closure of the material edition. Visuals may show equipment or accessories available as standard or optional depending of each country. Technical specifications belong to standard versions, which may vary from country to country. All the characteristics of this document are indicative data; GOUPIL Industrie reserves the right to modify without notice. Please contact your distributor for the latest news.

